

Title/Subject: Standard Application Procedures – Field Modifications		
CDS No.: ASAP2006	Page No. 1 of 17	
Original Issue Date: 1/1/1985	Follow-Up Review Date: 2/10/2008	Revision Date: 2/10/2005
Signature/Initial: Steven J. Luzik, Center Chief		

1.0 PURPOSE

- 1.1 To inform applicants how to apply for Mine Safety and Health Administration (MSHA) Field Modifications.
- 1.2 To specify the documentation and processing steps necessary to evaluate a field modification application compliant with MSHA requirements.
- 1.3 To identify the Applicant’s responsibilities during the investigation process.

2.0 SCOPE

This procedure applies to all mine owners who wish to apply for a field modification under Title 30 Code of Federal Regulations, Section 18.81 of approved (permissible) electric motor-driven mine equipment or electrical components of Part 36 diesel powered equipment.

3.0 REFERENCES

- 3.1 APOL2153 – “Policy on Motor Overload Protection”
- 3.2 APOL1009 – “Application Cancellation Policy”

4.0 DEFINITIONS

- 4.1 A&CC – the Approval and Certification Center.
- 4.2 Applicant – A mine owner, or their designate. The designate may be a mine superintendent, master mechanic, shop foreman, mine engineer, or other responsible mine official.
- 4.3 Approved (permissible) electric motor-driven mine equipment - As applied to electric face equipment, all equipment taken into or used in by the last open crosscut of an entry or room of any coal mine, or metal or non-metal mine designated as gassy by the Secretary, the parts

1.0 PURPOSE

- 1.1. To inform applicants how to apply for Mine Safety and Health Administration (MSHA) Field Modifications.
- 1.2. To specify the documentation and processing steps necessary to evaluate a field modification application compliant with MSHA requirements.
- 1.3. To identify the Applicant's responsibilities during the investigation process.

2.0 SCOPE

This procedure applies to all approved (permissible) equipment owners who wish to apply for a field modification under Title 30 Code of Federal Regulations, Section 18.81.

3.0 REFERENCES

- 3.1. APOL2153 – “Policy on Motor Overload Protection”
- 3.2. APOL1009 – “Application Cancellation Policy”

4.0 DEFINITIONS

- 4.1. A&CC – the Approval and Certification Center.
- 4.2. Applicant – A mine owner or their designate. The designate may be a mine superintendent, master mechanic, shop foreman, mine engineer, or other responsible mine official.

5.0 PROCEDURE

- 5.1. Application

TITLE: Field Modification Application Procedures

MSHA Mine Safety and Health Administration, Approval & Certification Center

- 5.1.1. An applicant who desires to modify equipment approved under 30 CFR, Part 18 must submit a written Field Modification Request to the A&CC. A separate request must be submitted for each different approval number of equipment modified, even though identical modifications are proposed. Different extensions of the same approval numbers may be covered under the same field modification request if the proposed modifications are relevant to each extension. Alternate or optional components cannot be added under the Field Modification Program.
- 5.1.2. All applications for Field Modification must include the following:
- 5.1.2.1. Two copies of the Field Modification Request. (See Appendix 1, Enclosure A for blank request forms, Enclosure B for a completed sample of the request form for Part 18 approved machines.)
- 5.1.2.2. Two copies of each drawing, bill of material, specification, etc., necessary for documenting the proposed modification(s).
- 5.1.2.3. Field Modification Requests should be mailed to:
- Approval and Certification Center
Mine Safety and Health Administration
RR #1, Box 251
Industrial Park Road
Triadelphia, West Virginia 26059
- 5.1.2.3.1. Applications may be submitted in electronic format. The procedure is available on the MSHA web page
<http://www.msha.gov/techsupp/acc/application/online.htm>.
- 5.1.3. Fee Authorization
- 5.1.3.1. Upon receipt of the Field Modification Request by A&CC, a letter will be written to the applicant and will include an estimate of the maximum anticipated fee to complete the investigation. An authorization response form will also be included in which the applicant agrees to pay expenses up

to the maximum estimated fee for the investigation or requests cancellation of the application. This form must be returned before any further action is taken on the application. If the form letter is not returned within 30 days from the date of the letter, the application will be canceled.

- 5.1.3.2. The applicant can pre-authorize the application by authorizing up to a certain dollar amount of investigation time in the application letter. This will permit MSHA to initiate the investigation while the fee estimation process is taking place.
- 5.1.3.3. If unforeseen circumstances are encountered during the investigation that results in exceeding the estimated fee, the applicant will be contacted and given the option of canceling the action or accepting the new estimated fee. When the fee authorization is returned to the A&CC, the technical investigation of the request will resume.

5.2. Application Requirements

- 5.2.1. A&CC requires detailed information concerning proposed modifications to approved (permissible) equipment. Properly presented information will contribute to the expeditious processing of each Field Modification Request.
- 5.2.2. The following information must be included on the application:
 - 5.2.2.1. Company name
 - 5.2.2.2. Mine name or number
 - 5.2.2.3. MSHA Portal ID number
 - 5.2.2.4. Mailing address to be used for the fee authorization, discrepancy letter, and field modification acceptance letter.
 - 5.2.2.5. Date of application
 - 5.2.2.6. Application Code Number. The application code number is a unique six (6) digit number assigned by the applicant used for application identification.

- 5.2.2.7. Type of equipment (continuous miner, shuttle car, etc.).
- 5.2.2.8. Manufacturer. The manufacturer is the original equipment manufacturer of the approved machine.
- 5.2.2.9. MSHA approval number, extension number, model number, and the serial number(s)
- 5.2.2.10. Voltage rating and current. The voltage rating of machine(s) and current (AC or DC) must be specified.
- 5.2.2.11. Number of machines changed
- 5.2.2.12. Machine location and date available for inspection. The machine inspection can be done at the mine site or at a rebuild shop. If necessary, this determination will be made through communications with the MSHA district office or the A&CC's Quality Assurance and Materials Testing Division.
- 5.2.2.13. Name and telephone number of a person to contact for additional information must be indicated. If available, a fax number or e-mail address may be added to aid communications. The contact person may be the rebuild shop who did the modifications or mine personnel.
- 5.2.2.14. Signature of responsible mine company official

5.3. Application Guidelines

- 5.3.1. The basic function of the equipment type cannot be changed by the field modification request (e.g., a continuous miner cannot be converted into a loading machine). Also, a machine built prior to Schedule 2G may be modified, but that part of the machine being modified must comply with current 30 CFR, Part 18 requirements.
- 5.3.2. The description of modification should be a narrative describing the modification(s) made to the equipment, including specific references to the

electrical components modified or added, in addition to providing details of the modification(s). (See Appendix No. 1, enclosures A and B)

- 5.3.3. The “Components Removed” section is a bill of materials for components removed. List and identify certified components removed from the modified machine. List and identify all other essential components that were removed (e.g., overload relays, packing glands, gland plugs, etc.). Cable and conduit information is not required in this section. All cable and gland parts should be listed on the packing gland and cable data sheets.
- 5.3.4. The “Components Added” section is a bill of materials for added components. Cable, conduit, and packing gland information is not required to be listed under the components added section.
- 5.3.5. If explosion-proof (certified) enclosures are removed or added, the type of enclosure must be specified including: the electrical rating (if applicable), the manufacturer, part number, and the MSHA Certification Number. Headlight enclosures must also include the voltage and wattage of the light bulb. Motors must be identified by the frame number, voltage, horsepower, and full load rating in amperes.
 - 5.3.5.1. If an explosion-proof enclosure is added that was accepted under an approval investigation, it must be identified by the model/part number and Approval Number of the machine under which it was evaluated.
 - 5.3.5.2. Except for special applications, all cable runs on a permissible machine must originate and terminate within a certified enclosure. A packing gland and cable data sheet must be completed for each cable run that was modified or added to the machine.
 - 5.3.5.3. In special applications, such as MSHA accepted intrinsically safe circuits, the cable run originates within a certified enclosure and terminates in most cases in a non explosion-proof enclosure. In this case the MSHA evaluation (IA) number must be specified for the intrinsically safe circuit.

- 5.3.5.4. The routing of a circuit extending from the permissible machine to a non-permissible area may be considered a special application. In this scenario, both ends of all ungrounded conductors must be fused at less than the ampacity rating of the cable, but cannot exceed 5 amperes. The fuse voltage ratings must be greater than the maximum voltage in either the permissible or non-permissible enclosure.
- 5.3.5.5. Motor overload information must be in accordance with APOL2153 – Policy on Motor Overload Protection (contact A&CC for copy).
- 5.3.5.6. Electrical cable conductor size, number of conductors, cable type (SO, G-GC, etc.), length, outside diameter (O.D.), and short-circuit protection must be documented. Cables between machine components are required to be MSHA approved as flame-resistant, unless they are totally enclosed in MSHA approved flame-resistant hose conduit.
- 5.3.5.7. The inside diameter (I.D.) and length must be provided for all hose conduit specified.
- 5.3.5.8. “From/To” is used to identify the certified enclosure where the cable run originates and where the cable run terminates, respectively. The enclosures should be identified by type, manufacturer, and certification number.

Examples: From: Control Station, Galis, X/P-1126-3
 To: Emergency Stop Sw., Ensign, X/P-1818-0

 From: Starter (original), Joy, 18-XPA030039-0
 To: Control Station, P/N 500186-5, 2G-2005-6

- 5.3.5.9. Information concerning the "Packing Gland and Cable Data Sheet" must be provided when any cable or packing gland parts are added or modified. However, when a packing gland and the cable are not modified by the proposed change, even though they are described on the data sheet, write “As Approved” across the packing gland component box.
- 5.3.5.10. The packing gland component manufacturer and part number is normally reported. In some cases an on file at A&CC drawing may be referenced

which specifies the part number. In the case where a vendor assigns a part number to the manufacturer part, the original part number must be specified. If a part is machined by the applicant or repair shop, a drawing must be submitted depicting the component with the machining dimensions, tolerances, and type of material.

- 5.3.5.11. Packing material: The cable's outer jacket must be in contact with the packing material for no less than 1/2" when the gland assembly is fully assembled. The packing material must be accepted by MSHA as flame resistant.
- 5.3.5.12. Packing gland grommets must be made of MSHA approved flame resistant material. The radial clearance between the cable jacket and the nominal inside diameter of the grommet shall not exceed 1/32", based on the nominal specified cable diameter. The radial clearance between the nominal outside diameter of the grommet and the inside wall of the stuffing box shall not exceed 1/32". The grommet must be in contact with the cable jacket for no less than 1/2" when the packing gland is fully assembled. (See Figure 1.)

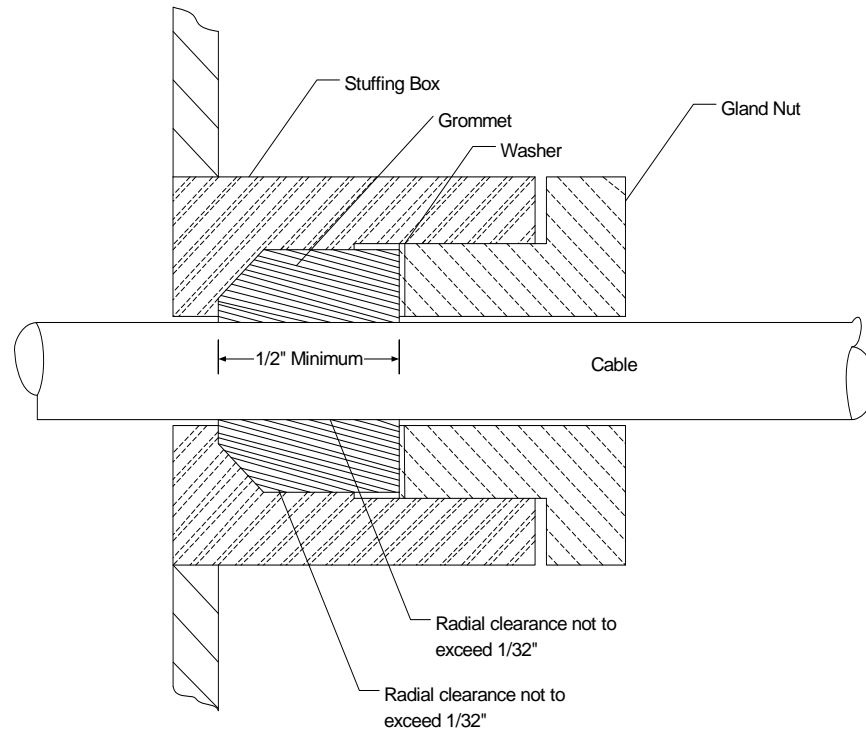

Figure 1

5.3.5.13. Remarks: Enter any remark that would clarify the reported information on the cable run data sheet.

5.3.5.14. For gland component measurement see Figures 2 and 3.

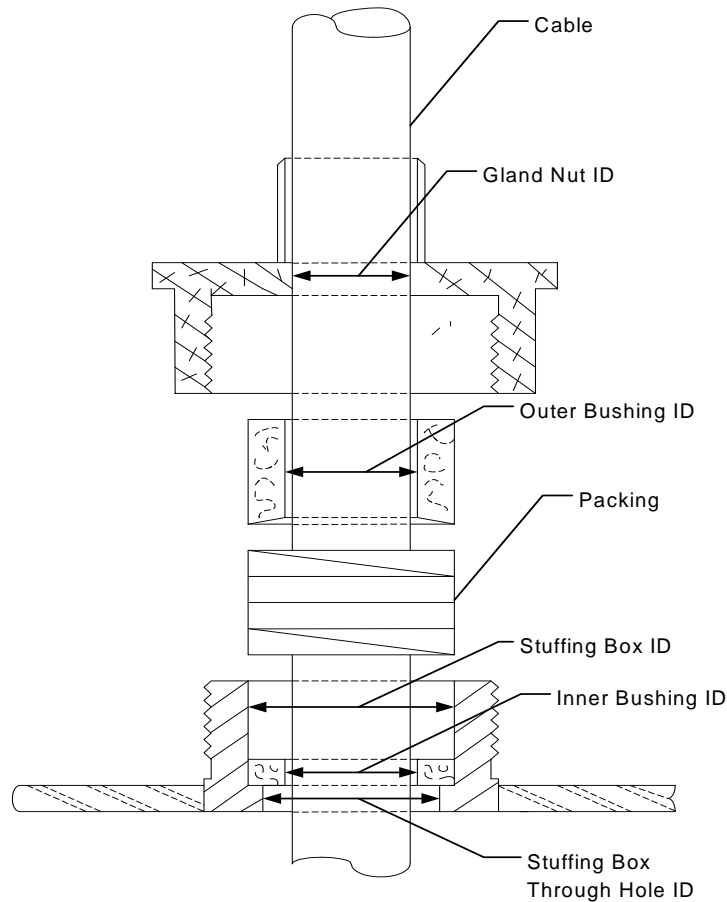

Figure 2. Typical Motor Gland Assembly

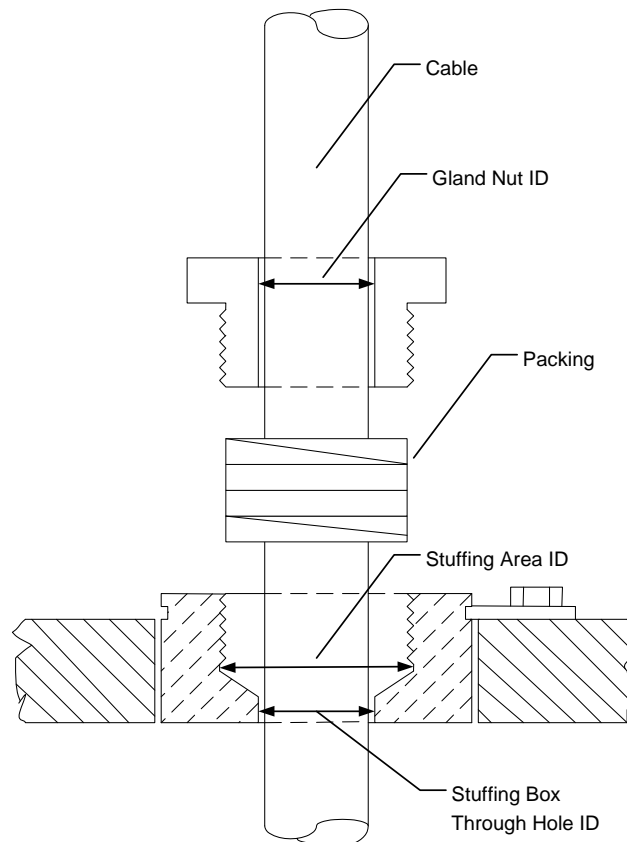

Figure 3. Typical Slip-In Gland Assembly

- 5.3.5.15. As an alternate to the Packing Gland and Cable Data Sheets, the applicant can submit a Component Layout/Bill of Materials drawing depicting all of the components and cable runs. Neither the component layout nor bill of materials can have optional or alternate components or cable listed.
- 5.3.5.16. Drawings of the packing gland assembly may be submitted, or drawings on file at A&CC may be referenced. Documentation of gland parts/assemblies not previously accepted must include the following dimensions:
- 5.3.5.16.1. Through holes of packing glands and nuts,

- 5.3.5.16.2. Packing areas,
 - 5.3.5.16.3. Packing material and size,
 - 5.3.5.16.4. Bushings (outside and inside diameters, and thickness),
 - 5.3.5.16.5. Threading, and
 - 5.3.5.16.6. Machining tolerances
 - 5.3.5.16.7. When assembled, the gland nut must have at least 3 threads engaged and have 1/8" or more to travel before meeting interference by parts other than the packing material.
 - 5.3.5.17. Schematic diagram (indicating the changes)
 - 5.3.5.17.1. A schematic diagram may have highlighted areas, inked-in notations, or blacked-out areas shown on the drawing, but it cannot depict optional or alternate settings or components. All information depicted on drawings submitted must be legible.
 - 5.3.5.18. Photographs or other supporting documentation may be submitted.
 - 5.3.5.18.1. Any device not previously accepted at A&CC must be evaluated, and all requested information must be provided by the applicant or vendor before the application can be processed.
 - 5.3.5.19. A checklist has been developed as an aid to the applicant. The checklist applies only to those components/parts being modified. The checklist does not need to be submitted with the application. (See Appendix No. 2.)
 - 5.3.5.20. The above information is considered the minimum necessary for processing field modification applications. Except for drawings and other related specifications, the required information should be provided on "Field Modification Application" forms and data sheets. (See Appendix No. 1.)
- 5.4. Technical Investigation

- 5.4.1. The assigned A&CC investigator will evaluate the change(s) to determine if they meet the applicable requirements of 30 CFR, Part 18. The applicant will be notified of any discrepancies, or if additional information is needed to process the application. All requests for additional information must be addressed in a timely manner or the application will be subject to cancellation. (Ref. APOL1009 – “Application Cancellation Policy” – contact A&CC for copy.)
- 5.4.2. When the technical evaluation is completed and all discrepancies are corrected, a copy of the field modification request will be forwarded to the appropriate MSHA district office. The MSHA district office will assign an inspector to verify the information documented in the application. The A&CC may also inspect the application at the repair facility. In this case, the application will not be forwarded to the MSHA district office until the Field Modification acceptance letter is sent.
- 5.4.3. A&CC investigators can only verify approval documentation. They cannot provide approval drawings or proprietary information about the approved machine or its components. If the applicant needs this type of information, it must be obtained from the MSHA approval holder.
- 5.5. Equipment Inspection Preparation
- 5.5.1. The machine(s) must be made available for inspection within six (6) months after notification that the application has been evaluated or the application will be cancelled.
- 5.5.2. The equipment must be prepared by the applicant for examination by MSHA personnel in the following manner:
- 5.5.2.1. The equipment must be located where it will be free from obstruction and unsafe conditions.
- 5.5.2.2. Personnel must be provided to assist in the examination.
- 5.5.2.3. The flanges and interior of each enclosure affected by the change, including the cover, must be cleaned thoroughly.

5.5.2.4. All modified or added hoses, cables, and cords must be cleaned to expose surface markings.

5.5.2.5. All electrical components must be cleaned to reveal all stampings, identification plates, and certification plates.

5.6. Inspection

5.6.1. The physical inspection of the machine(s) will include, but may not be limited to, the following:

5.6.1.1. A general inspection of the machine to determine if it is being maintained in permissible condition,

5.6.1.2. An inspection of all components affected by the modification,

5.6.1.3. Adequacy of mechanical protection of cables, adequacy of cable strain clamps, and positioning of cables, particularly the proximity to hydraulic lines and pinch points,

5.6.1.4. Adequacy of guarding against physical damage to headlights, pushbuttons, switch operators or any other vulnerable electrical components, and

5.6.1.5. The ratings and settings of overload and short-circuit protective devices.

5.6.2. After completing the field inspection, the MSHA district office will send a Field Modification Inspection Report to A&CC. If no discrepancies are found, a short memorandum to that effect will be sufficient (See Appendix 1, Enclosure C for sample.) If minor discrepancies are found, the inspector may require the applicant to correct the application documentation and submit corrections to the A&CC or include the corrections in the report (See Appendix 1, Enclosure D for sample.) If the discrepancies are extensive, the inspector will forward a list of the discrepancies to the A&CC for reevaluation (See Appendix 1, Enclosure E for sample), and if necessary, require the applicant to correct the application documentation. A copy of any revised documents submitted must be retained by the applicant in order to ensure that the documentation matches the records on file at A&CC.

5.6.3. If the MSHA district office determines that the modification constitutes a hazard due to the particular mine environment in which the machine(s) will operate, or the Field Modification Request is not in compliance with the applicable provisions of 30 CFR, Parts 57 or 75, the district office will notify A&CC that the request should not be accepted. (See Appendix 1, Enclosure F for sample.)

5.7. Acceptance

5.7.1. If the application is determined by A&CC to meet all applicable requirements, a letter of Field Modification Acceptance will be sent to the applicant. An invoice for the total cost of the investigation will then follow. Copies of the notification will also be sent to the district office.

5.8. Additional Modifications

5.8.1. An applicant is not required to submit a Field Modification Request to A&CC for certain modifications. In these cases, the applicant must notify the MSHA district office in writing of the changes. Inspection of the modification may be made at the discretion of the district manager. A copy of all notifications should be maintained in the appropriate mine file. Field modification requests that don't require a request to the A&CC include:

5.8.1.1. Addition of methane monitors (excluding methane monitors that tie into the shutdown systems of diesel equipment)

5.8.1.2. Field modifications duplicating the original equipment manufacturer's approved design of an essentially identical machine. For example, a shuttle car with approval number 2G-2000-0 may have been originally approved without an emergency stop switch. Subsequently, the manufacturer filed an application and received approval from A&CC to install a specific switch, X/P-1000-0 on all new shuttle cars. These shuttle cars would bear Approval Number 2G-2000-1, or the first extension of the original approval. An operator owning a shuttle car with the original approval 2G-2000-0 and wishing to add an emergency stop switch can contact the manufacturer. If

the switch X/P-1000-0 is installed as approved under the first extension, it is not necessary to notify A&CC.

- 5.8.1.3. Field modifications duplicating previously accepted field changes for machines of the same type and with the same approval number at the same mine or under the direction of the same maintenance supervisor(s).
- 5.8.1.4. Installation of silicon diode grounding equipment in existing explosion-proof enclosures on machines, provided no cable gland openings are made in the machine and provided the installation meets the requirements of 30 CFR 75.703-3(d) which refers to voltage and current ratings, and over current protection for such devices.
- 5.8.1.5. Removal of non-safety-related electrical components from a machine. For example, relocation of the headlight resistors to the machine control box would eliminate the headlight resistor enclosures. All unused cable entrances must be plugged, and plugs must be secured in place in accordance with Part 18 requirements.
- 5.8.1.6. Changes that are made within explosion-proof enclosures and do not conflict with permissibility requirements. Circuit breakers, overload relays, and fuse protection must be maintained as originally approved.
- 5.8.1.7. Change of trailing cables on machines with cable reels having external trailing cable connections from flat to round or vice versa, from a G to G-GC or vice versa, and changes to a larger cable size, provided the insulated trailing cable strain clamp still grips the cable properly and provided no changes are made to the cable entrance glands.
- 5.8.1.8. Change of trailing cable from G to G-GC or vice versa on machines with direct cable entry into an enclosure. Changes in the physical cable size (outside diameter) require cable entry modification and a field change application and report. Cables that are the same size electrically may not have the same outside diameters due to insulation differences.

- 5.8.1.9. Change in the length of the trailing cable to maximum allowable as shown in Table 9 of 30 CFR, Part 18.
- 5.8.1.10. Modification involving installation of illumination systems that are covered under a Statement of Test and Evaluation (STE) or the interchanging of alternate lighting fixtures of STE lighting systems that have been found by A&CC to have similar photometric patterns.
- 5.8.1.11. Installation of any electrical components of a braking system required by 30 CFR, Section 18.20(f).
- 5.8.1.12. Insulation of cable reels or battery box lids with material that has been accepted by MSHA.
- 5.8.1.13. Interchanging of certified headlamps that meet Part 18 requirements and are designed to accept the same size cable. Replacement lamps in these headlamps must be in conformance with the headlamp certification.
- 5.8.1.14. Substitution of a certified or approved battery and tray assembly for an assembly on an existing machine.
- 5.8.1.15. Relocation of electrical components on a machine, provided the interconnecting cables meet the requirements of 30 CFR, Section 18.36(b).

APPENDIX NO. 1

TITLE 30 CFR, PART 18

FIELD MODIFICATION FORMS

FIELD MODIFICATION APPLICATION

Chief
Approval and Certification Center
RR #1, Box 251
Industrial Park Road
Triadelphia, West Virginia 26059

Company: _____
Mine: _____
Portal I.D. No.: _____
Address: _____

Application Code No.: _____

Date: _____

Gentlemen:

We are requesting acceptance of a field modification, pursuant to Title 30 CFR Part 18.81, of the following equipment:

Equipment type: _____

Manufacturer: _____

Approval No.: _____ Model No.: _____ Voltage _____ AC or DC

Number of machines changed: _____ Serial No.(s): _____

The machine(s) will be available for inspection on _____
(date)

At _____
(location)

Enclosed are two (2) copies of all drawings and specifications related to the modification.

If there are any questions, please contact (Mr./Ms.) _____

at _____
(Telephone, FAX, E-mail)

Sincerely yours,

(Signature of Mining Company Representative)

(Print or Type Mining Company Representative Name and Title)

Enclosure A, (Sht. 1)

3. Description of Components Removed:

<u>COMPONENT</u>	<u>MANUFACTURER</u>	<u>Part No.</u>	<u>MSHA Cert. No. (X/P)</u>
_____	_____	_____	_____
_____	_____	_____	_____
_____	_____	_____	_____
_____	_____	_____	_____
_____	_____	_____	_____
_____	_____	_____	_____
_____	_____	_____	_____
_____	_____	_____	_____
_____	_____	_____	_____
_____	_____	_____	_____
_____	_____	_____	_____
_____	_____	_____	_____
_____	_____	_____	_____
_____	_____	_____	_____
_____	_____	_____	_____
_____	_____	_____	_____
_____	_____	_____	_____
_____	_____	_____	_____
_____	_____	_____	_____
_____	_____	_____	_____
_____	_____	_____	_____

(If additional space is needed, attach additional sheets)
Enclosure A, (Sht. 3)

PACKING GLAND AND CABLE DATA SHEET

Sheet No.: ___ of ___

Complete Description of Modified and/or Additional Packing Glands and Cable Runs

CABLE - Type: _____ Conductors: _____ Size: _____ O.D.: _____

Cable Length: _____ Is cable flame-resistant? _____

Short-Circuit Protection: _____

Overcurrent Protection: _____

Hose Conduit - I.D.: _____ Length: _____

From: _____ To: _____

Item--Mfg.--Cert. No. (X/P)

Item--Mfg.--Cert. No. (X/P)

Packing Gland Components	I.D.	Component Mfg. and Part No.
Stuffing Box Thru Hole		
Inner Bushing		
Outer Bushing		
Gland or Gland Nut		
Hose Tube		
Packing Size		
Stuffing Area		

I.D.	Component Mfg. and Part No.

Is the stuffing box welded inside and outside? _____

Is cable enclosed in flame-resistant hose conduit? _____

Are the hose conduits securely clamped? _____

Is the packing material asbestos or MSHA accepted substitute? _____

Remarks: _____

FIELD MODIFICATION APPLICATION

Chief
Approval and Certification Center
RR #1, Box 251
Industrial Park Road
Triadelphia, West Virginia 26059

Company: Northwest Chemical Corp.
Mine: Trestle Mine
Portal I.D. No.: 48-90347
Address: R.D. 5, Box 72
Green River, Utah 75849

Application Code No.: 000025

Date: November 11, 2004

Gentlemen:

We are requesting acceptance of a field modification, pursuant to Title 30 CFR Part 18.81, of the following equipment:

Equipment type: Roof Drill

Manufacturer: Jay Goode Co.

Approval No.: 2G-9751A-1 Model No.: DD0-15 Voltage: 480 AC or DC
Number of machines changed: 3 Serial No(s): 70475, 70476, and 70482

The machine(s) will be available for inspection on May 11, 1997
(date)

at Northwest Chemical Corp. Central Shop, Durham Road, Price, Utah
(location)

Enclosed are two (2) copies of all drawings and specifications related to the modification.

If there are any questions, please contact (Mr./Ms.) William Palmer

at (411) 291-1380 Fax: Unavailable E-mail: Unavailable
(Telephone, FAX, or E-mail)

Sincerely yours,

Bill Palmer

Mine Mechanic

Enclosure B, (Sht. 1)

2. Concise Description of Modification:

The 75 hp electric pump motor, X/P-4476-2, was replaced by a similar 75 hp, 68 FLA motor, X/P-4476-7.

No changes were made in the cable or packing glands. A Warren Electric stop button (remote) was added.

This necessitated a nipple (1221-A) to be installed in the right end plate of the starter box (X/P-4407-0) and an appropriate packing gland assembly was added to accept the added #14-3/c Type SO cable.

The stop button is protected by a Warren Electric Intrinsic Safe Relay, Model 123-W, IA-925-1, installed in the starter box.

(If additional space is needed, attach additional sheets)

Enclosure B, (Sht. 2)

PACKING GLAND AND CABLE DATA SHEET

Sheet No.: 1 of 2

Complete Description of Modified and/or Additional Packing Glands and Cable Runs

CABLE - Type: SHD-GC Conductors: 3 Size: 2/0 AWG O.D.: 2.00 inch

Cable Length: 10 feet Is cable flame-resistant? Yes

Short-Circuit Protection: Circuit breaker set at 1500 amp max
OL's Wesley Electric, Code CA, Range 68-75 amp,
 Overcurrent Protection: trip amps 81

Hose Conduit - I.D.: 2-1/2 inch Length: 10 feet
 Starter Box

From: Jay Goode, X/P-4407-0 To: Motor, Smithfield, X/P-4478-94
Item--Mfg.--Cert. No. (X/P) Item--Mfg.--Cert. No. (X/P)

Packing Gland Components	I.D.	Component Mfg. and Part No.
Stuffing Box Thru Hole	2.390" ± .01	Steel
Inner Bushing	2.188" ± .01	Brass
Outer Bushing	2.188" ± .01	Brass
Gland or Gland Nut	2.196" ± .01	Steel
Hose Tube		N/A
Packing Size	3/8"	N/A
Stuffing Area	2.650" +.01/-0.03	Steel

I.D.	Component Mfg. and Part No.
2.75	Smithfield 609029-3A
2.66"	Smithfield 609030-5B
2.66"	Smithfield 609030-5B
2.76"	Smithfield 609031-1X
	N/A
1/2"	N/A
2.96"	Smithfield 609029-3A

Is the stuffing box welded inside and outside? Yes

Is cable enclosed in flame-resistant hose conduit? No

Are the hose conduits securely clamped? Yes

Is the packing material asbestos or MSHA accepted substitute? Yes

Remarks:

Sheet No.: 2 of 2

Complete Description of Modified and/or Additional Packing Glands and Cable Runs

CABLE - Type: SO Conductors: 3 Size: 14 AWG O.D.: .67"

Cable Length: 12 feet Is cable flame-resistant? No

Short-Circuit Protection: Protected by IA-925-1

Overcurrent Protection: N/A

Hose Conduit - I.D.: 3/4" Length: 10 feet

Starter Box Stop Button

From: Jay Goode Co., X/P-4407-0 To: Warren Elec., Model R4321

Item--Mfg.--Cert. No. (X/P) Item--Mfg.--Cert. No. (X/P)

Packing Gland Components	I.D.	Component Mfg. and Part No.
Stuffing Box Thru Hole	.75" ± .01	Steel
Inner Bushing	N/A	
Outer Bushing	N/A	
Gland or Gland Nut	.75" ± .01	Brass
Hose Tube		N/A
Packing Size	3/8"	N/A
Stuffing Area	1.00" +.01/- .03	Steel

I.D.	Component Mfg. and Part No.
N/A	IS Circuit

Is the stuffing box welded inside and outside? Yes

Is cable enclosed in flame-resistant hose conduit? Yes

Are the hose conduits securely clamped? Yes

Is the packing material asbestos or MSHA accepted substitute? Yes

Remarks:

MEMORANDUM FOR JOHN P. FAINI

Chief, Approval and Certification Center

THROUGH: JOHN J. JONES
District Manager
Coal Mine Safety and Health
District 5

FROM: SAMUEL S. SMITH
Mine Inspector (Electrical)

SUBJECT: Field Modification Inspection Report
A&CC Par No. 82356

The modifications have been examined and compared to the described changes on the application. There were no discrepancies found and the modifications were judged not to increase the fire and explosive hazards involved in the operation of this machine in gassy or dusty mines.

Enclosure D

MEMORANDUM FOR JOHN P. FAINI
Chief, Approval and Certification Center

THROUGH: JOHN J. JONES
District Manager
Coal Mine Safety and Health
District 5

FROM: SAMUEL S. SMITH
Mine Inspector (Electrical)

SUBJECT: Field Modification Inspection Report
A&CC Par No. 82356

The modifications have been examined and compared to the described changes on the application. The following discrepancies were found:

- 1) The connection box listed on the Description of Components Added sheet and the Packing Gland and Cable Data Sheet No. 1 of 2 was identified as serial number 37148L, but the manufacturer's plate listed it as 3714BL. The manufacturer was contacted and the serial number 3714BL is correct.
- 2) The fuses providing protection for the headlight circuit were specified as 10 amperes, but one of the fuses installed was rated at 20 amperes. It was replaced with a properly rated fuse.

All discrepancies were corrected and the modifications were judged not to increase the fire and explosive hazards involved in the operation of this machine in gassy or dusty mines.

Enclosure E

MEMORANDUM FOR JOHN P. FAINI

Chief, Approval and Certification Center

THROUGH: JOHN J. JONES
District Manager
Coal Mine Safety and Health
District 5

FROM: SAMUEL S. SMITH
Mine Inspector (Electrical)

SUBJECT: Field Modification Inspection Report
A&CC Par No. 82356

The modifications have been examined and compared to the described changes on the application. The connection box listed on the Description of Components Added sheet and the Packing Gland and Cable Data Sheet No. 1 of 2 was identified as a Smith Manufacturing Company enclosure accepted under Approval No. 2G-8000-1, but the box installed was a Johnson Machine Company enclosure certified as X/P-8254-6. The two sheets affected by this change were corrected to show this information. Please verify that the enclosure and gland parts listed on the Data Sheet were accepted under the certification records.

No other discrepancies were found. The physical modifications were judged not to increase the fire and explosive hazards involved in the operation of this machine in gassy or dusty mines.

Enclosure F

MEMORANDUM FOR JOHN P. FAINI

Chief, Approval and Certification Center

FROM: JOHN J. JONES
District Manager
Coal Mine Safety and Health
District 5

SUBJECT: Field Modification Inspection Report
A&CC Par No. 82356

The modifications have been examined and compared to the described changes on the application. There were no discrepancies found regarding the requirements of 30 CFR, Part 18. However, 30 CFR, Part 75.342(a)(2) requires an additional methane monitor sensing device to be installed on the longwall shearing machine, which the applicant has failed to provide.

In regard to the Field Modification Request replacing the longwall shearing machine, we are requesting that the request be denied until or unless the provisions of 30 CFR, Part 75.342(a)(2) are met.

Enclosure G

APPENDIX NO. 2

TITLE 30 CFR, PART 18

FIELD MODIFICATION CHECKLIST

FIELD MODIFICATION CHECKLIST

- ___ 1. Are all electrical components installed in locations where they are protected from physical damage during normal operation of the machine or is suitable guarding provided?
- ___ 2. Is a means provided by which all power conductors, including any being added or modified, can be deenergized at the machine? NOTE: If the machine is equipped with a methane monitor, the methane monitor must deenergize all circuits on the machine, including any being added or modified, except the methane monitor circuit.
- ___ 3. Are all certified enclosures being added or removed identified in the data sheets as to manufacturer and certification number or the approval number under which it was accepted?
- ___ 4. Are all electrical components solidly secured to the machine frame?
- ___ 5. Are intrinsically safe circuit conductors separated from power conductors?
- ___ 6. Are strain relief devices provided for trailing cable and remote cables/cords?
- ___ 7. Is short-circuit provided for any added cables and overcurrent protection provided for any added motors?
- ___ 8. Do cables which are not totally enclosed in hose conduit have flame-resistant properties as indicated by an MSHA number?
- ___ 9. Are all cables between electrical components:
 - ___ a. Clamped in place to prevent undue movement?
 - ___ b. Protected from mechanical damage by position, flame-resistant hose conduit, metal tubing or troughs? NOTE: Flexible or threaded rigid metal conduit is not acceptable.
 - ___ c. Isolated from hydraulic lines and components?

- ___ d. Protected from abrasion by removing all sharp corners or edges which they may contact?

- ___ 10. Are electrical components inside explosion-proof enclosures insulated where space is limited?

- ___ 11. Are lock-washers provided for all bolts, screws, or studs that secure parts of explosion-proof enclosures?

- ___ 12. When additional holes are drilled in an enclosure, for fastenings, is at least one-eighth inch of stock left in the bottom of the holes to ensure that the holes do not penetrate to the interior of explosion-proof enclosures?

- ___ 13. Are the holes for fastenings threaded to a depth such that the bolts or screws will not bottom when lockwashers are omitted?

- ___ 14. Are precautions taken to ensure that none of the fastenings used for joints on explosion-proof enclosures are used to attach non-essential parts or for making electrical connections?

- ___ 15. Are all threaded covers secured from loosening by a locking screw, wire, or other means?

- ___ 16. Are the joints forming the flame-arresting paths on the explosion-proof enclosures (flanges and covers) smooth, free from rust, corrosion, and pitting?

- ___ 17. Are the joints securely fastened so that an appropriate size feeler gauge cannot be inserted around the perimeter of any enclosure cover?

- ___ 18. Are all new or modified enclosures free from unnecessary through holes, weakness in welds, or flaws in castings?

- ___ 19. Do all added or modified packing gland assemblies comply with the following:
 - ___ a. Assembled so that the cable jacket penetrates into the interior of the enclosure?

 - ___ b. Have a minimum of one-eighth inch clearance between the packing nut and the stuffing box?

 - ___ c. Is the packing nut secured from loosening by a locking screw, wire, or other means?

 - ___ d. The gland nuts have a minimum of three full threads engaged.

20. Are accurate measurements and part numbers for the packing gland assembly parts included in the data sheets for the following:
- ___ a. Through hole (I.D.)
 - ___ b. Stuffing area (I.D.)
 - ___ c. Inner bushing (I.D.)
 - ___ d. Outer bushing (I.D.)
 - ___ e. Packing nut (I.D.)
 - ___ f. Hose tube (I.D.)
 - ___ g. Cable (O.D.)
 - ___ h. Diameter or size of asbestos packing
- ___ 21. Is hose conduit securely clamped to hose tube?
- ___ 22. Are all unused lead entrances closed with metal plugs which are secured in place by spot welding, brazing, or equivalent method?

NOTE: When assembled, the compressed packing must be in contact with the cable jacket for a distance of at least one-half inch.